



FL18.6LT
Bucket technical characteristics

Dimensions

D1: 300 mm

D2: 254 mm

H: 362 mm *without the lid*

Deviation ±1mm

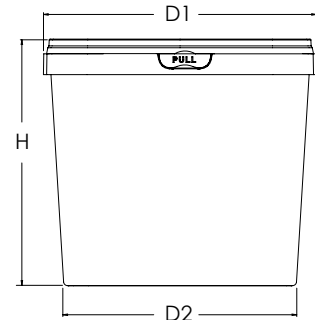

Other elements

Capacity (LT)

Volume to rim
18.200 LT

Brim full volume
20.700 LT

Net weight / Deviation (±2.5%)

550 gr

Handle

Metallic

Weight 47 gr

Buckets packaging

Pallet 252 pcs

Decoration

IML Label
924X274 mm

Packaging

3 Vertically

Lid technical characteristics

FL18.6LT

Dimensions

D: 275 mm

H: 211 mm

Απόκλιση ±1mm

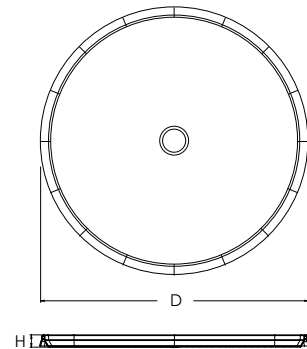
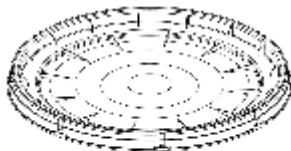

Other elements

Lid weight (gr)
Deviation (±2.5%)

125 gr

Lid packaging

Pallet 960 pcs

USEFUL STORAGE INFORMATION: To preserve the quality of this product, it is recommended that it be stored in its original packaging, away from any source of local heat and moisture, away from direct sunlight (below 30°C) and dry conditions. It is recommended that the product be allowed to reach operating temperature 24 hours before use.

RAW MATERIAL: Polypropylene (PP)



ISO 22000/ISO 9001/FSSC 22000

